

ACCU COLOR

ARCHITECTURAL BATTERY RGBWA-PROJECTOR

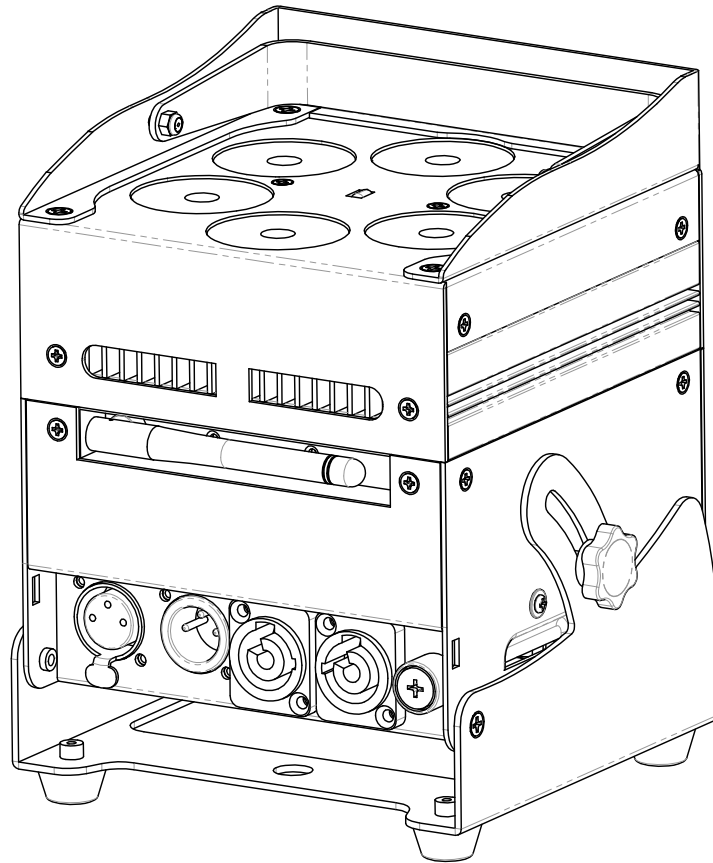

ENGLISH

Operation Manual

Other languages can be downloaded from:
WWW.JB-SYSTEMS.EU

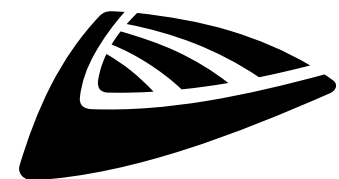

Version: 1.0

JB SYSTEMS



EN - DISPOSAL OF THE DEVICE

Dispose of the unit and used batteries in an environment friendly manner according to your country regulations.

FR - DÉCLASSER L'APPAREIL

Débarrassez-vous de l'appareil et des piles usagées de manière écologique Conformément aux dispositions légales de votre pays.

NL - VERWIJDEREN VAN HET APPARAAT

Verwijder het toestel en de gebruikte batterijen op een milieuvriendelijke manier conform de in uw land geldende voorschriften.

DU - ENTSORGUNG DES GERÄTS

Entsorgen Sie das Gerät und die Batterien auf umweltfreundliche Art und Weise gemäß den Vorschriften Ihres Landes.

ES - DESHACERSE DEL APARATO

Reciclar el aparato y pilas usadas de forma ecologica conforme a las disposiciones legales de su país.

PT - COMO DESFAZER-SE DA UNIDADE

Tente reciclar a unidade e as pilhas usadas respeitando o ambiente e em conformidade com as normas vigentes no seu país.

OPERATION MANUAL

Thank you for buying this JB Systems® product. To take full advantage of all possibilities and for your own safety, please read these operating instructions very carefully before you start using this unit.

FEATURES

- Battery operated LED-projector, based on 6pcs 10Watt RGBWA-LEDs to avoid unwanted color shadows.
- Beam angle = 22°
- Projection angle can be adjusted over 25° (vertical to horizontal)
- The perfect solution for many applications: exhibition booths, parties, special events, ...
- +/-10hrs use in fading mode on a fully charged battery!
- Each projector is equipped with a wireless transceiver module (transmitter and receiver) which is 100% compatible with the W-DMX G4-protocol from "Wireless Solution Sweden".
- Projector can still be used with empty battery: just connect it to the mains!
- Very smooth RGBWA color changes thanks to high freq. dimming electronics
- The internal battery charger charges the battery while the projector is working on mains power.
- The projector comes with a transparent plastic cover to protect it against rain (IP20) so it can be used outdoor to light up trees, plants, walkways,...
- Different working modes:
 - Standalone: custom colors selectable or automatic and beat synchronized color changes
 - Master/slave mode: wonderful preprogrammed, music synchronized lightshows.
 - DMX-controlled : cabled and wireless. (5 modes : 4-5-9-10 channels, LEDCON-02 Mk2)
 - Controlled by a small JBS LEDCON-02 Mk2 and LEDCON-XL controller
 - Controlled by wireless IR remote control
- ProCon mains in/outputs: easy daisy chaining of several units (if needed).

BEFORE USE

- Before you start using this unit, please check if there's no transportation damage. Should there be any, do not use the device and consult your dealer first.
- **Important:** This device left our factory in perfect condition and well packaged. It is absolutely necessary for the user to strictly follow the safety instructions and warnings in this user manual. Any damage caused by mishandling is not subject to warranty. The dealer will not accept responsibility for any resulting defects or problems caused by disregarding this user manual.
- Keep this booklet in a safe place for future consultation. If you sell the fixture, be sure to add this user manual.

Check the contents:

Check that the packing contains the following items:

- Operating instructions
- Accu Color
- Mains cable
- Wireless IR remote control
- Transparent plastic cover

SAFETY INSTRUCTIONS:



CAUTION
RISK OF ELECTRIC SHOCK
DO NOT OPEN



CAUTION: To reduce the risk of electric shock, do not remove the top cover. No user-serviceable parts inside. Refer servicing to qualified service personnel only.



The lightning flash with arrowhead symbol within the equilateral triangle is intended to alert the user or the presence of un-insulated "dangerous voltage" within the product's enclosure that may be of sufficient magnitude to constitute a risk of electric shock.



The exclamation point within the equilateral triangle is intended to alert the user to the presence of important operation and maintenance (servicing) instructions in the literature accompanying this appliance.



This symbol means: indoor use only
IP43 outdoor while used with the optional cover



This symbol means: Read instructions



This symbol determines: the minimum distance from lighted objects. The minimum distance between light-output and the illuminated surface must be more than 1 meters



The device is not suitable for direct mounting on normally flammable surfaces. (suitable only for mounting on non-combustible surfaces)

RISK GROUP 2
CAUTION:
Do not stare at operating lamp

CAUTION: Do not stare at operating lamp.
May be harmful to the eyes.

- To protect the environment, please try to recycle the packing material as much as possible.
- To prevent fire or shock hazard, do not expose this appliance to rain or moisture.
- To avoid condensation to be formed inside, allow the unit to adapt to the surrounding temperatures when bringing it into a warm room after transport. Condense sometimes prevents the unit from working at full performance or may even cause damages.
- This unit is for indoor use only.
- Don't place metal objects or spill liquid inside the unit. Electric shock or malfunction may result. If a foreign object enters the unit, immediately disconnect the mains power.
- Locate the fixture in a well ventilated spot, away from any flammable materials and/or liquids. The fixture must be fixed at least 50cm from surrounding walls.
- Don't cover any ventilation openings as this may result in overheating.
- Prevent use in dusty environments and clean the unit regularly.
- Keep the unit away from children.
- Inexperienced persons should not operate this device.
- Maximum safe ambient temperature is 40°C. Don't use this unit at higher ambient temperatures.
- Make sure the area below the installation place is free from unwanted persons during rigging, de-rigging and servicing.
- Allow the device about 10 minutes to cool down before to start servicing.
- Always unplug the unit when it is not used for a longer time or before to start servicing.
- The electrical installation should be carried out by qualified personal only, according to the regulations for electrical and mechanical safety in your country.
- Check that the available voltage is not higher than the one stated on the unit.
- The power cord should always be in perfect condition. Switch the unit immediately off when the power cord is squashed or damaged. It must be replaced by the manufacturer, it's service agent or similarly qualified persons in order to avoid a hazard.
- Never let the power-cord come into contact with other cables!
- This fixture must be earthed in order to comply with safety regulations.
- Don't connect the unit to any dimmer pack.
- Always use an appropriate and certified safety cable when installing the unit.
- In order to prevent electric shock, do not open the cover. There are no user serviceable parts inside.
- **Never** repair a fuse or bypass the fuse holder. **Always** replace a damaged fuse with a fuse of the same type and electrical specifications!
- In the event of serious operating problems, stop using the fixture and contact your dealer immediately.
- The housing and the lenses must be replaced if they are visibly damaged.
- Please use the original packing when the device is to be transported.

- Due to safety reasons it is prohibited to make unauthorized modifications to the unit.

Important: Never look directly into the light source! Don't use the effect in the presence of persons suffering from epilepsy.

DESCRIPTION:

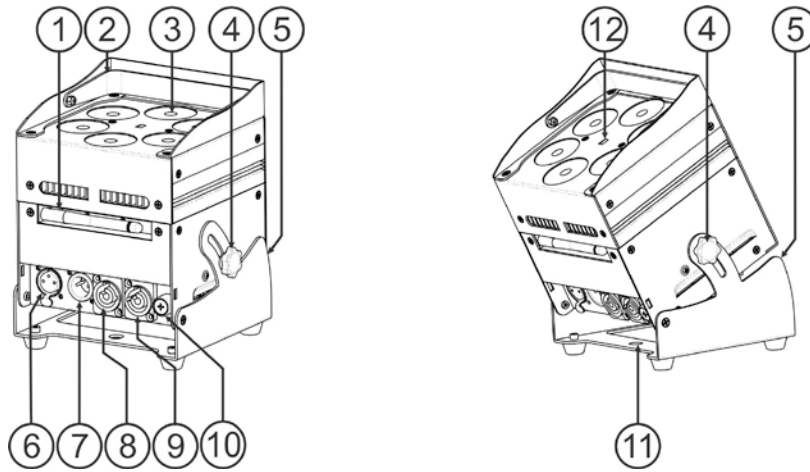

1. Antenna for wireless connection
2. Handle to easily carry the projector.
3. Lens in front of RGBWA 10W LED
4. Knob used to fasten the projector in a desired angle between 0° and 25°.
5. Projector base.
6. DMX Output connector XLR Female 3P.
7. DMX Input connector XLR Male 3P.
8. Mains output with ProCon connector : you can use a special XLR/Powercon cable to connect up to max. 16A (power).
9. Mains input with ProCon connector : you can use a special XLR/Powercon cable to connect up to max. 16A (power).
10. Fuse holder with glass fuse: replace with the correct fuse, see technical information
11. Hole to use the base as hanging bracket to fix the projector in truss, using a mounting hook.
12. IR sensor
13. [ID-Set] button : used to connect projector wireless to another projector. (see chapter : [HOW TO SETUP])
14. Test button : push this button to check the battery status (25 – 50 – 75 or 100% charged)
15. [Wireless DMX] Indicator : shows the wireless status (see chapter : [HOW TO SETUP])
16. Microphone : allows the projector to work in audio-mode.
17. [Power ON/OFF] button : push this button to turn the projector ON or OFF
18. Audio sensitivity button : turn this button left or right to adjust the microphone's sensitivity to sound.
19. [MENU] button : push this button to select the desired topic in the menu
20. ▲ button : push this button to go up in the menu
21. Display
22. ▼ button : push this button to go down in the menu
23. [ENTER] button : push this button to confirm the selected setting
24. [Wireless ON/OFF] button : push this button to switch ON or OFF the wireless transmitter/receiver in the projector.

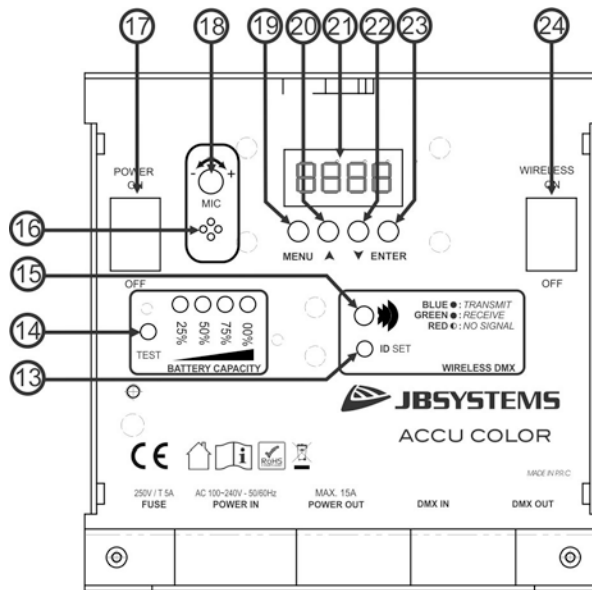

ELECTRICAL INSTALLATION

⚠ Important: The electrical installation should be carried out by qualified personal only, according to the regulations for electrical and mechanical safety in your country.

Note: In the explanations below we assume that you will operate the projectors with the internal battery which is already fully charged. If you want to use them with a mains cable, simply connect all projectors to the mains using the supplied power cable.

Electrical installation for 1 standalone unit:

- Switch the projector on using the power switch (17). The unit starts working immediately in the last selected stand-alone mode.
- Refer to chapter [HOW TO SETUP] to learn how to switch between different working modes.

Electrical installation for two or more units in master/slave:

- Make sure that all units are switched on.
- Setup 1 unit as Master (see [SETUP MENU]) and wireless transmitter (see [SETUP FOR WIRELESS OPERATION]). Setup the other units as Slave (see [SETUP MENU]) and wireless receiver (see [SETUP FOR WIRELESS OPERATION])
- Done

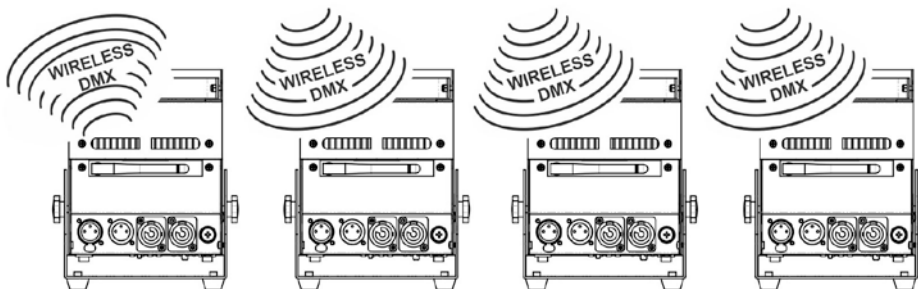

Remark: You can connect a JBS LEDCON-02 Mk2 remote controller to the master unit if you want to have more control over the master/slave operation.

Electrical installation for two or more units in DMX-mode:

You can control the Accu Color by DMX in different ways, depending on your needs. You can go for a wired solution (using cables), you can go for a completely wireless solution or you can go for a combination of both...

WIRELESS SOLUTION

- Switch all projectors on.
- Put all projectors in the desired DMX-channel mode (see chapter [HOW TO SETUP]: option [CHnd])
- Set the desired DMX start address on all projectors, take in account the number of DMX channels used by the selected DMX-channel mode! (see chapter [HOW TO SETUP]: option [Addr])
- Switch on the wireless mode using switch (24).
- Synchronize all projectors with the wireless DMX transmitter. (for example : Briteq® “WT-DMXG4” transmitter is 100% compatible)
- Once this is done everything should work.

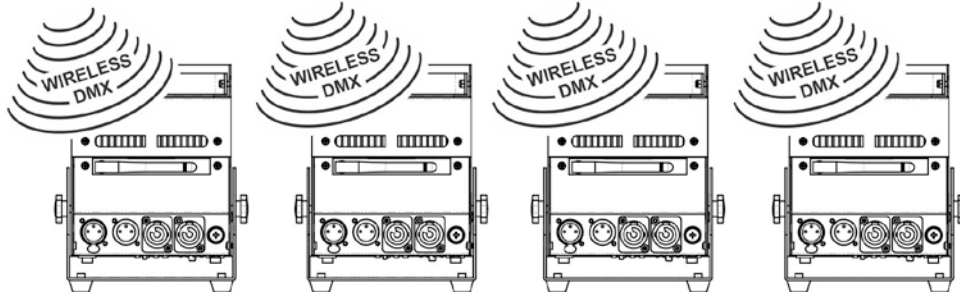

MIXED SOLUTION

- Daisy chain all projectors using good quality balanced microphone/DMX cables.
- Switch all projectors on.
- Put all projectors in the desired DMX-channel mode (see chapter [HOW TO SETUP]: option [ChMd])
- Set the desired DMX start address on all projectors, take in account the number of DMX channels used by the selected DMX-channel mode! (see chapter [HOW TO SETUP]: option [Addr])
- Synchronize the first projector in the DMX-chain with the wireless DMX transmitter (for example : Briteq® “WT-DMXG4” transmitter is 100% compatible): (see chapter [HOW TO SETUP])
- Once this is done, the first unit is controlled by wireless DMX and will pass the DMX-signal to the other projectors via the wired DMX-chain.

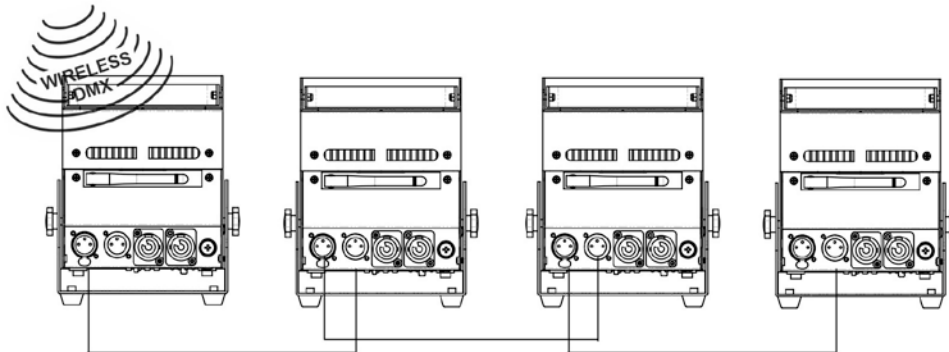

WIRED SOLUTION

- Same as the MIXED solution but the first unit in the chain also receives the DMX-signal from a DMX-cable plugged in its DMX-input connector.

Note: when a DMX-signal is detected on the DMX-input connector, this “wired” DMX-signal will take precedence over the wireless DMX-signal.

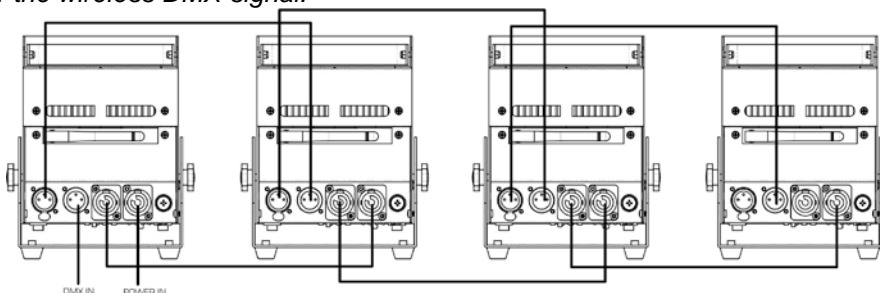

USING THE TRANSPARENT COVER

- **INDOOR USE (IP20):** you can use the projector without the transparent cover.
- **OUTDOOR USE (IP43):** you can use the plastic transparent cover to avoid rain from entering the projector.

Attention: *this does NOT mean that the projector now becomes full waterproof! It's only protected against occasional rain!*



[SETUP MENU]:

MAIN MENU:

- To select any of the menu options, press the **[MENU]** button.
- Use **▲** and **▼** button to choose the desired menu option..
- Select the function with the **[ENTER]** button. The display will blink.
- Once the required menu option is selected, press the **[ENTER]** button to select.
- Press the **[MENU]** button to return to running mode.

[Addr] DMX 512 Address setting

Used to set the start address in a DMX setup.

- Press the **[MENU]** button.
- Press the **▲** or **▼** button until **[Addr]** is shown on the display.
- Press the **[ENTER]** button to select. The display starts blinking.
- Use **▲** and **▼** buttons to change the DMX512 address.
- Once the correct address is shown on the display, press the **[ENTER]** button to confirm.

[CHnd] Channel Mode

The unit has 5 different channel modes, refer to the DMX-chart to see the differences.

- Press the **[MENU]** button.
- Press the **▲** or **▼** button until **[CHnd]** is shown on the display.
- Press the **[ENTER]** button to select. The display starts blinking.
- Use **▲** and **▼** buttons to select one of the available channel modes.
- Once the mode is selected, press the **[ENTER]** button to confirm.

[SLAU] Slave Mode

The first projector in the chain should be set , all the other projectors have to be in Slave mode.

- Press the **[MENU]** button.
- Press the **▲** or **▼** button until **[SLAU]** is shown on the display.
- Press the **[ENTER]** button to select. The display starts blinking.
- Then press **[ENTER]** to confirm the slave mode.

[SP--] Speed Mode

- Press the **[MENU]** button.
- Press the **▲** or **▼** buttons until **[SP--]** is shown on the display.
- Press the **[ENTER]** button to select. The display starts blinking.
- Use **▲** and **▼** buttons to select the desired speed.

[Pr--] Preset Selection Mode

Used to choose to select one of the preprogrammed colors or fades when used in standalone or master/slave mode. All projectors will always show an identical output.

- Press the **[MENU]** button.
- Press the **▲** or **▼** buttons until **[Pr--]** is shown on the display.

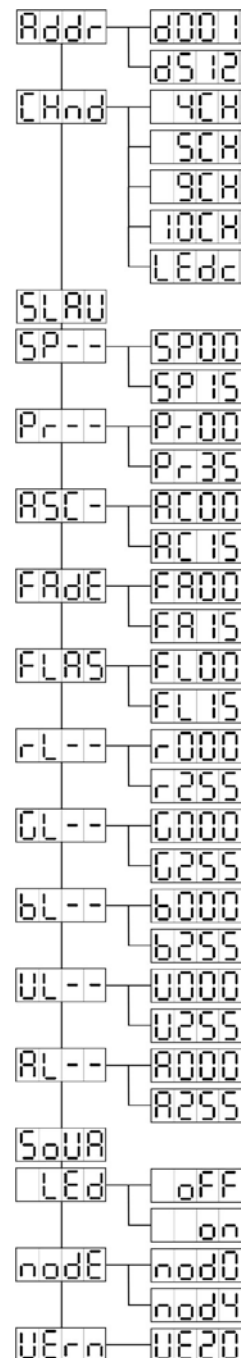

- Press the [ENTER] button to select. The display starts blinking.
- Use ▲ and ▼ buttons to select one of the preprogrammed colors or shows. (Pr01...Pr35)
- Once the desired color or show is selected, press the [ENTER] button to confirm.

[ASC-] Mode

Used to choose the desired color changing show.

- Press the [MENU] button.
- Press the ▲ or ▼ buttons until [ASC-] is shown on the display.
- Press the [ENTER] button to select.
- Use ▲ and ▼ button to select one of the available shows (AC00...AC15)
- Once the desired show is selected, press the [ENTER] button to confirm.

[FAde] Mode

Used to choose a color fading show

- Press the [MENU] button.
- Press the ▲ or ▼ buttons until [FAde] is shown on the display.
- Press the [ENTER] button to select. The display starts blinking.
- Use ▲ and ▼ button to select a value between [FA00] (fast fading) and [FA15] (slow fading).
- Once the desired mode is selected, press the [ENTER] button to confirm.

[FLAS] Strobe Mode

Used to select the strobe speed.

- Press the [MENU] button.
- Press the ▲ or ▼ buttons until [FLAS] is shown on the display.
- Press the [ENTER] button to select. The display starts blinking.
- Use ▲ and ▼ buttons to select the speed (FL00...FL15)
- Once the desired speed is selected, press [ENTER] to confirm.

[rL--] Mode

Used to set the minimum value of the Red color

- Press the [MENU] button.
- Press the ▲ or ▼ buttons until [rL--] is shown on the display.
- Press the [ENTER] button to select. The display starts blinking.
- Use ▲ and ▼ buttons to select the speed (r000...r255)
- Once the desired value is selected, press [ENTER] to confirm.

[GL--] Mode

Used to set the minimum value of the Green color

- Press the [MENU] button.
- Press the ▲ or ▼ buttons until [GL--] is shown on the display.
- Press the [ENTER] button to select. The display starts blinking.
- Use ▲ and ▼ buttons to select the speed (G000...G255)
- Once the desired value is selected, press [ENTER] to confirm.

[bL--] Mode

Used to set the minimum value of the Blue color

- Press the [MENU] button.
- Press the ▲ or ▼ buttons until [bL--] is shown on the display.
- Press the [ENTER] button to select. The display starts blinking.
- Use ▲ and ▼ buttons to select the speed (b000...b255)
- Once the desired value is selected, press [ENTER] to confirm.

[UL--] Mode

Used to set the minimum value of the White color

- Press the [MENU] button.
- Press the ▲ or ▼ buttons until [UL--] is shown on the display.
- Press the [ENTER] button to select. The display starts blinking.
- Use ▲ and ▼ buttons to select the speed (U000...U255)

- Once the desired value is selected, press [ENTER] to confirm.

[AL--] Mode

Used to set the minimum value of the Amber color

- Press the [MENU] button.
- Press the ▲ or ▼ buttons until [AL--] is shown on the display.
- Press the [ENTER] button to select. The display starts blinking.
- Use ▲ and ▼ buttons to select the speed (A000...A255)
- Once the desired value is selected, press [ENTER] to confirm.

[SoUA] Sound Mode

Used to make shows working on sound or not.

- Press the [MENU] button.
- Press the ▲ or ▼ buttons until the display shows [SoUA].
- Press [ENTER] button to select. The display starts blinking.
- Press [ENTER], the projector is now working in sound mode.
If you want to go back to normal running mode: press the [MENU] button.

[Led] Mode

Led on : display is always on.

Led off : display is off when not used.

- Press the [MENU] button.
- Press the ▲ or ▼ buttons until the display shows [LEd].
- Press [ENTER] button to select. The display starts blinking and shows [on] or [oFF]
- Select [on] or [oFF] by pressing the ▲ or ▼ button.
- Press [ENTER] to select the desired mode.
- The display will turn off after some time.
- The display will turn on again by pressing one of the buttons [MENU], [▲], [▼] or [ENTER]

[node] Function

Used to slow down the dimming speed.

- Press the [MENU] button.
- Press the ▲ or ▼ buttons until the display shows [node].
- Press the [ENTER] button. The display starts blinking and shows [nod0...nod4]
- Use ▲ and ▼ buttons to select [nod0...nod4] where 0 is the fastest and 4 the slowest mode.
- Once the desired mode is selected, press the [ENTER] button to confirm.

[UErn] Software Version

Used to show the software version of the unit.

- Press the [MENU] button.
- Press the ▲ or ▼ buttons until the display shows [UErn].
- Press the [ENTER] button. The display starts blinking and shows the version [UE2.0].
- Press the [MENU] button to leave.

[SETUP FOR WIRELESS OPERATION]

Each unit has a wireless DMX transceiver on board. This means that every unit can be transmitter or receiver.

To set up the system, you first need to assign each receiver to the universe (transmitter) it should work with.

VERY IMPORTANT THINGS TO KNOW BEFORE USE

Before you start using these wireless DMX units, you should know about the following some basic information. It will save you a lot of time and frustration:

- A DMX-controller (switched on) should be connected to the transmitter while synchronizing receivers.
- Check information on the [ID-SET] button (13) and status led (15).
 - Status LED (15) WHITE : unit is in setup mode or disconnected from any transmitter.
 - Status LED (15) BLUE : unit is in TRANSMITTER mode and connected to one or more receivers.
 - Status LED (15) BLUE (blinking fast) : unit (transmitter) is connecting to receiver(s).
 - Status LED (15) BLUE (blinking slow) : no DMX-signal present on transmitter
 - Status LED (15) GREEN : unit is connected to a transmitter
 - Status LED (15) GREEN (blinking slow) : unit receives no DMX-signal from transmitter.
- A receiver can only connect to a transmitter while it is completely disconnected: status led (15) is WHITE.

SETTING UP THE TRANSMITTER

- Be sure a DMX-controller (switched ON) is connected to the transmitter and the unit is switched ON.
- Push the [ID-SET] button (13) while turning ON the Wireless button (24). The status LED (15) will become WHITE for a second and then turns into BLUE (transmitter mode) or GREEN (receiver mode).
- Choose BLUE by pushing the [ID-SET] button (13) shortly.
- Once BLUE selected, push the [ID-SET] button (13) for 3 seconds to confirm the transmitter mode.
- The status LED will turn white, red, green and ends on BLUE.
- The unit is now in transmitter mode.

CONNECTING ONE OR SEVERAL RECEIVERS TO A TRANSMITTER

To connect your receiver(s) to a specific transmitter:

- a) Make sure that the receivers to be connected are not linked to another transmitter: the status led (15) on these receivers should be WHITE.
- b) Press the [ID-SET] button (13) of the transmitter shortly; the status led (15) on both the transmitter (BLUE) and receivers (GREEN) starts blinking.
- c) Wait until blinking stops: the receivers are now linked to the transmitter.
- d) Check if the connection was made properly: press the [ID-SET] button (13) on the transmitter again, the status led (15) on all linked receivers start blinking. Receivers linked to another transmitter will not blink.

DISCONNECTING RECEIVERS FROM A DMX UNIVERSE

To disconnect all the receivers from a DMX universe / transmitter:

- Press the [ID-SET] button (13) of the transmitter for about 5 seconds until the status LED (15) turns RED, the status LED on the receiver(s) turn WHITE (disconnected).
- After a few moments the status LED (15) on the transmitter turns BLUE again.
- You can also re-connect the receiver(s) again simply by pushing shortly on the [ID-SET] button (13) on the transmitter. (The status LED (15) on the receiver(s) turns GREEN again.

To disconnect an individual receiver from a DMX universe / transmitter:

- Press the [ID-SET] button (13) of the receiver until the status LED (15) is WHITE.
- This receiver is now disconnected from the transmitter (DMX universe).

OPERATING INSTRUCTIONS

A. Standalone 1unit:

- Select one of the automatic modes or select a fixed color
- Select the static or sound control mode
- Refer to chapter [HOW TO SETUP] to learn how to make the previous settings.

B. Two or more units in master/slave setup:

- Connect 2 to maximum 16 units together. Refer to the chapter “electrical installation” to learn how to do this.
- Set the slave mode for each projector: the first one must be set on in DMX mode or in a show mode (for example : [FADE])
- Connect all units to the mains. The units will start working automatically and show the internal chase programs.

Remark: You can connect a JBS LEDCON-02 Mk2 remote controller to the master unit if you want to have more control over the master/slave operation. All projectors must be in LEDc mode!

C. Connect an optional JBS LEDCON-02 Mk2 controller for more control:

The JBS LEDCON-02 Mk2 controller can only be used in standalone or master/slave mode. Connect the controller to the DMX-input of the first unit (master). Make sure that the Accu Color projectors are all set to channel mode [LEDc]. Now you can control all the connected units in 4 or 8channel mode. Refer to the user manual of the JBS LEDCON-02 Mk2 controller for more information.

D. Controlled by IR remote-controller:

Switch on the projector (17). Push button [ON] on the IR remote controller. [Jr00] will appear on the display. You are now ready to use the IR remote controller.

When you turn the projector off with the IR remote controller, [Jr0F] will be shown on the display.

Before you can start using the projector with another controller you have to push one of the buttons under the display ([MENU]-[▲]-[▼]-[ENTER]). The projector will now be disconnected from the IR remote controller.

You can also use the IR remote controller with several projectors in Master-slave mode. Select the desired color, fade on the Master. The slaves will follow the instructions from the Master projector.

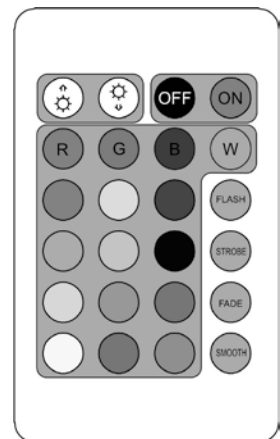

E. Controlled by universal DMX-controller:

- Connect all units together. Refer to the chapter “Electrical installation for two or more units in DMX-mode” to learn how to do this (don’t forget to address all units properly!)
- Turn on the DMX controller.

Since each unit has its own DMX-address, you can control them individually. Remember that each unit uses 4 to 10 DMX-channels as shown in the DMX charts below:

DMX CHARTS

Mode 4CH:

DMX Channel	DMX-value	function	remarks
1	000-255	Color mixing 0% - 100%	
2	000-255	White color dimmer	WHITE
3	000-255	Amber color dimmer	AMBER
4	000-255	Master Dimmer 0% - 100%	MASTER DIMMER

Mode 5CH:

DMX Channel	DMX-value	function	remarks
1	000-255	Red color dimmer	RED
2	000-255	Green color dimmer	GREEN
3	000-255	Blue color dimmer	BLUE
4	000-255	White color dimmer	WHITE
5	000-256	Amber color dimmer	AMBER

Mode 9CH:

DMX Channel	DMX-value	function	remarks
1	000-255	Master Dimmer 0% - 100%	MASTER DIMMER
2	000-255	Red color dimmer	RED
3	000-255	Green color dimmer	GREEN
4	000-255	Blue color dimmer	BLUE
5	000-255	White color dimmer	WHITE
6	000-255	Amber color dimmer	AMBER
7	000-014	Open	STROBE
	015-255	Strobe Slow to fast	
8	000-031	Open	AUTOMATIC MODES
	032-063	Close-open	
	064-095	Open-close	
	096-127	Open-close-open (white)	
	128-159	Color fading	
	160-191	Open-close-open (colors)	
	192-223	Color changing	
224-255	Sound		
9	000-255	Speed automatic modes 0% -100%	SPEED AUTOMATIC MODES

Mode 10CH:

DMX Channel	DMX-value	function	remarks
1	000-255	Master Dimmer 0% - 100%	MASTER DIMMER
2	000-255	Red color dimmer	RED
3	000-255	Green color dimmer	GREEN
4	000-255	Blue color dimmer	BLUE
5	000-255	White color dimmer	WHITE
6	000-255	Amber color dimmer	AMBER
7	000-014	Open	STROBE
	015-255	Strobe Slow to fast	
8	000-031	Open	AUTOMATIC MODES
	032-063	Close-open	
	064-095	Open-close	
	096-127	Open-close-open (white)	
	128-159	Color fading	
	160-191	Open-close-open (colors)	
	192-223	Color changing	
224-255	Sound		
9	000-255	Speed automatic modes 0% -100%	SPEED AUTOMATIC MODES
10	000-005		Uses the nodE setting
	006-055		Dimmer 0 (fast)
	056-105		Dimmer 1
	106-155		Dimmer 2

	156-205		Dimmer 3
	206-255		Dimmer 4 (slow)

4 channel DMX-Mode: all pixels working together in RGB + MASTER DIM/SOUND/STROBE

Channel:	Value:	Function:	Remarks
1	000-255	Red (0-100%)	
2	000-255	Green (0-100%)	
3	000-255	Blue (0-100%)	
4	000-190	Master dimmer	000=0% ~ 190=100% (full open)
	191-200	Sound control (7 colors)	Audio sensitivity: 191=low - 200=high
	201-247	Strobe	Increasing speed: 201=slow ~ 247=fast
	248-255	Master dimmer @ 100%	Master dimmer is full open

MAINTENANCE

- Switch off the unit and unplug the mains cable.

During inspection the following points should be checked:

- When an optical lens is visibly damaged due to cracks or deep scratches, it must be replaced.
- The mains cables must be in impeccable condition and should be replaced immediately when even a small problem is detected.
- In order to protect the device from overheat the cooling fans (if any) and ventilation openings should be cleaned monthly.
- **BATTERY maintenance:** We strongly advice to follow the maintenance requirements imposed by the battery reseller. On top of that you should at least every 6 months:
 - Do a visual check of the battery: cleanness, terminal damage, any damage of the housing, ...
 - Check the if the poles of the battery are still well tightened to the wires.
 - ...

Attention: We strongly recommend internal cleaning to be carried out by qualified personnel!

RECYCLING OF USED BATTERIES: used Li-Ion batteries should be considered and handled as dangerous waste. Each country has its own regulations for the recycling of used rechargeable batteries: check the local regulations in your country or ask your battery vendor for more information on recycling of the used rechargeable batteries!

SPECIFICATIONS

This unit is radio-interference suppressed. This product meets the requirements of the current European and national guidelines. Conformity has been established and the relevant statements and documents have been deposited by the manufacturer.

This device was designed to produce decorative effect lighting and is used in light show systems.

Mains Input:	100-240V, 50/60HZ
Power consumption:	60 Watt
ProCon input/output daisy chaining:	16A max. (be aware for current peeks at start up!)
Rechargeable battery:	11,1Vdc / 15600 mAh (lithium)
Sound Control:	Internal microphone
DMX connections:	XLR 3pin
LEDs:	6 LEDs 5IN1 10W
Beam angle:	22°
Size:	167 x 138 x 185mm
Weight:	3.7 kg

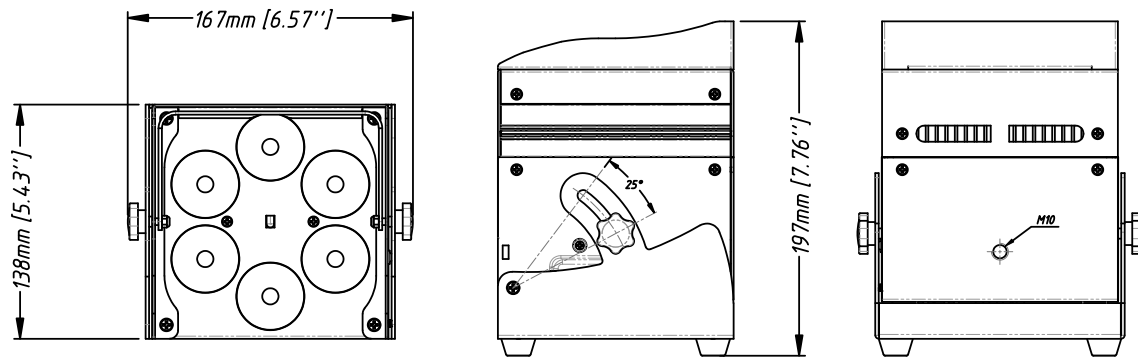

Every information is subject to change without prior notice
You can download the latest version of this user manual on our website: www.jb-systems.eu



JB SYSTEMS

MAILING LIST

EN: Subscribe today to our mailing list for the latest product news!

FR: Inscrivez-vous à notre liste de distribution si vous souhaitez suivre l'actualité de nos produits!

NL: Abonneer je vandaag nog op onze mailinglijst en ontvang ons laatste product nieuws!

DE: Abonnieren Sie unseren Newsletter und erhalten Sie aktuelle Produktinformationen!

ES: Suscribete hoy a nuestra lista de correo para recibir las últimas noticias!

WWW.JB-SYSTEMS.EU

Copyright © 2016 by BEGLEC NV

t Hofveld 2C ~ B1702 Groot-Bijgaarden ~ Belgium

Reproduction or publication of the content in any manner, without express permission of the publisher, is prohibited.